



RoHS Directive compatibility information
<http://www.mew.co.jp/ac/e/environment/>

FEATURES

1. Slim size (width 5 mm .197 inch, height 12.5 mm .492 inch) permits higher density mounting

Despite the slim 5 mm width, the 20 mm length is still compact and the 12.5 mm profile is low. Even when a socket is used, the height is still only 18 mm. Suitable for high-density mounting, these relays enable device size smaller.

2. Nominal operating power: High sensitivity of 120mW

Enables smaller power supplies, facilitates energy saving applications, and contributes to device size smaller.

3. Control from low level loads to 5 A

Use of gold-clad twin contacts enables control of low level loads down to 100 mV 100 μ A and up to 5 A 250 V AC and 30 V DC.

4. Reinforced according to IEC1131-2 (TÜV)

5. High surge breakdown voltage (4000 V) and high breakdown voltage (2000 V)

Between contacts and coil of 2,000 V and surge resistance of 4,000 V work to prevent controller malfunctions caused by noise and surges.

6. Outstanding vibration and shock resistance.

Functional shock resistance: 147 m/s²

Functional vibration resistance:

10 to 55 Hz (at double amplitude of 2.5 mm .098 inch)

Keeps equipment from miss-operation due to vibration and shock.

Can be used as mounted on control panel doors.

7. Sealed construction allows automatic washing.

8. SIL (single in line) terminal layout

9. Complies with safety standards

Complies with Japanese Electrical Appliance and Material Safety Law, and certified by UL, CSA, and TÜV.

10. Sockets are also available

TYPICAL APPLICATIONS

1. Industrial equipment, office equipment

2. Measuring devices and test equipment

3. Interface relays for programmable controllers

4. Output relays in small devices such as timers, counters, sensors, and temperature controllers.

ORDERING INFORMATION

PA 1a -

Contact arrangement
 1a: 1 Form A (Bifurcated)

Coil voltage (DC)
 5, 6, 9, 12, 18, 24V

Note: UL/CSA, TÜV approved type is standard.

TYPES

| Contact arrangement | Nominal coil voltage | Part No. |
|---------------------|----------------------|----------|
| 1 Form A | 5V DC | PA1a-5V |
| | 6V DC | PA1a-6V |
| | 9V DC | PA1a-9V |
| | 12V DC | PA1a-12V |
| | 18V DC | PA1a-18V |
| | 24V DC | PA1a-24V |

Standard packing: Carton: 25 pcs.; Case: 1,000 pcs.

RATING

1. Coil data

| Nominal coil voltage | Pick-up voltage (at 20°C 68°F) | Drop-out voltage (at 20°C 68°F) | Nominal operating current [$\pm 10\%$] (at 20°C 68°F) | Coil resistance [$\pm 10\%$] (at 20°C 68°F) | Nominal operating power | Max. allowable voltage (at 20°C 68°F) |
|----------------------|--|--|---|---|-------------------------|---------------------------------------|
| 5V DC | 70%V or less of nominal voltage *1 (Initial) | 5%V or more of nominal voltage*1 (Initial) | 24mA | 208Ω | 120mW | 120%V of nominal voltage |
| 6V DC | | | 20mA | 300Ω | | |
| 9V DC | | | 13.3mA | 675Ω | | |
| 12V DC | | | 10mA | 1,200Ω | | |
| 18V DC | | | 6.7mA | 2,700Ω | | |
| 24V DC | | | 7.5mA | 3,200Ω | 180mW*2 | |

Notes: *1 Pulse drive (JIS C 5442)

*2 24V DC, 120mW type are also available, please consult us.

2. Specifications

| Characteristics | Item | Specifications | |
|--|---|--|--|
| Contact | Arrangement | 1 Form A | |
| | Initial contact resistance, max. | Max. 30 mΩ (By voltage drop 6 V DC 1A) | |
| | Contact material | Au-clad AgNi type | |
| Rating | Nominal switching capacity (resistive load) | 5 A 250 V AC, 5 A 30 V DC | |
| | Max. switching power (resistive load) | 1,250 VA, 150 W | |
| | Max. switching voltage | 250 V (AC), 110 V (DC) | |
| | Max. switching current | 5 A | |
| | Nominal operating power | 120 mW (5 to 18 V DC), 180 mW (24 V DC) | |
| | Min. switching capacity (Reference value)*1 | 100μA 100mV DC | |
| Electrical characteristics | Insulation resistance (Initial) | Min. 1,000MΩ (at 500V DC) Measurement at same location as "Initial breakdown voltage" section. | |
| | Breakdown voltage (Initial) | Between open contacts | 1,000 Vrms for 1min. (Detection current: 10mA.) |
| | | Between contact and coil | 2,000 Vrms for 1min. (Detection current: 10mA.) |
| | Surge breakdown voltage (Initial) | Between contacts and coil*2 | 4,000 V |
| | Temperature rise (at 20°C 68°F) | | Max. 45°C (By resistive method, nominal voltage applied to the coil, nominal switching capacity.) |
| | Operate time (at nominal voltage) (at 20°C 68°F) | | Max. 10 ms |
| Release time (at nominal voltage) (at 20°C 68°F) | | Max. 5 ms | |
| Mechanical characteristics | Shock resistance | Functional | Min. 147 m/s ² (Half-wave pulse of sine wave: 11 ms; detection time: 10μs.) |
| | | Destructive | Min. 980 m/s ² (Half-wave pulse of sine wave: 6 ms.) |
| | Vibration resistance | Functional | 10 to 55 Hz at double amplitude of 2.5 mm (Detection time: 10μs.) |
| | | Destructive | 10 to 55 Hz at double amplitude of 3.5 mm |
| Expected life | Mechanical | Min. 2×10 ⁷ (at 180 cpm) | |
| | Electrical | Min. 10 ⁵ (3 A 250 V AC, 30 V DC, resistive load) Min. 5×10 ⁴ (5 A 250 V AC, 30 V DC, resistive load) (at 20 cpm) | |
| Conditions | Conditions for operation, transport and storage*3 | Ambient temperature: -40°C to 70°C -40°F to 158°F; Humidity: 5 to 85% R.H. (Not freezing and condensing at low temperature) | |
| | Max. operating speed (at rated load) | 20 cpm | |
| Unit weight | | Approx. 3 g .15 oz | |

Notes: *1 This value can change due to the switching frequency, environmental conditions, and desired reliability level, therefore it is recommended to check this with the actual load.

*2 Wave is standard shock voltage of $\pm 1.2 \times 50\mu s$ according to JEC-212-1981

*3 Refer to 6. Conditions for operation, transport and storage mentioned in AMBIENT ENVIRONMENT.

REFERENCE DATA

1. Max. switching capacity

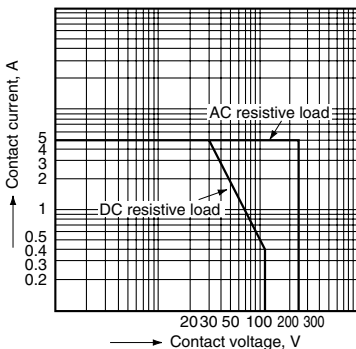

2. Life curve

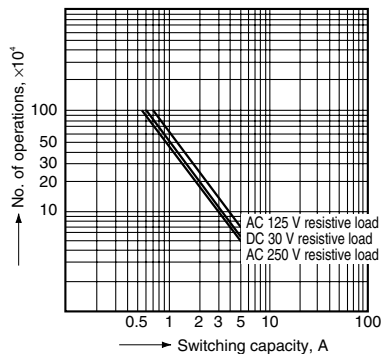

3.-(1) Coil temperature rise (120 mW)

Tested sample: PA1a-12V
Measured portion: Inside the coil
Ambient temperature: 20°C 68°F

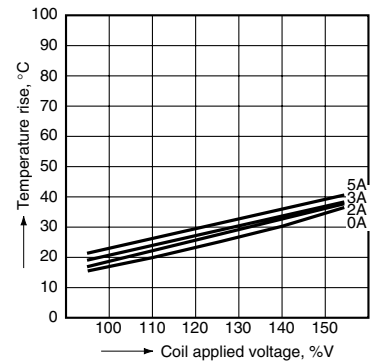

PA

3.-(2) Coil temperature rise (180 mW)

Tested sample: PA1a-24V
 Measured portion: Inside the coil
 Ambient temperature: 20°C 68°F

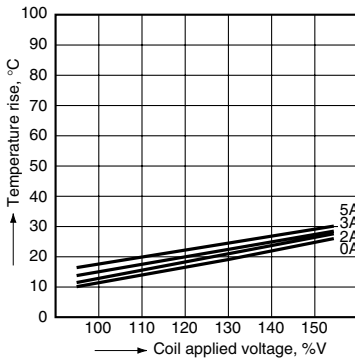

4.-(1) Operate & release time (120 mW)

Tested sample: PA1a-12V, 20 pcs.

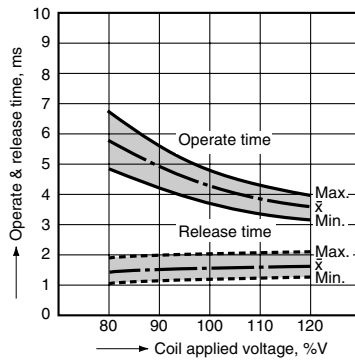

4.-(2) Operate & release time (180 mW)

Tested sample: PA1a-24V, 20 pcs.

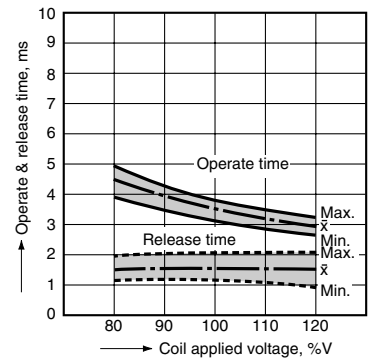

5. Ambient temperature characteristics

Tested sample: PA1a-12V, 6 pcs.

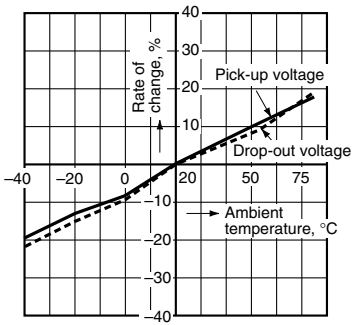

6. Malfunctional shock

Tested sample: PA1a-12V, 6 pcs.

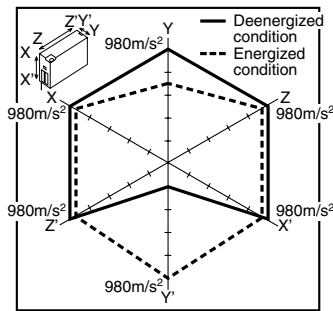

DIMENSIONS (Unit: mm inch)

Relay



External dimensions

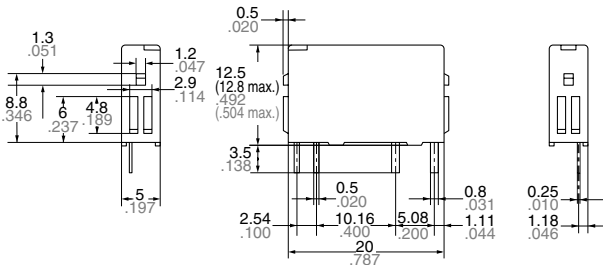

General tolerance: $\pm 0.3 \pm .012$

PC board pattern (Bottom view)

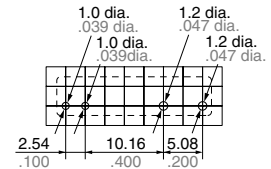

Tolerance: $\pm 0.1 \pm .004$

Schematic (Bottom view)

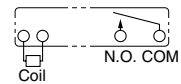

PA Socket

1. Standard type (PA1a-PS)

External dimensions



PA1a-PS

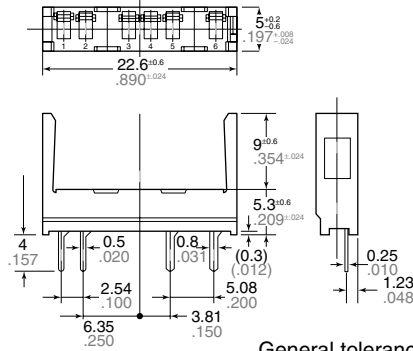

General tolerance: $\pm 0.3 \pm 0.12$

PC board pattern (Bottom view)

PA1a-PS

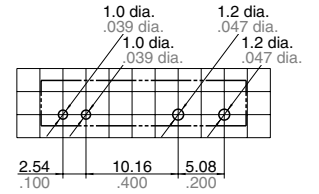

Tolerance: $\pm 0.1 \pm 0.04$

2. Self clinching type (PA1a-PS-H)

External dimensions

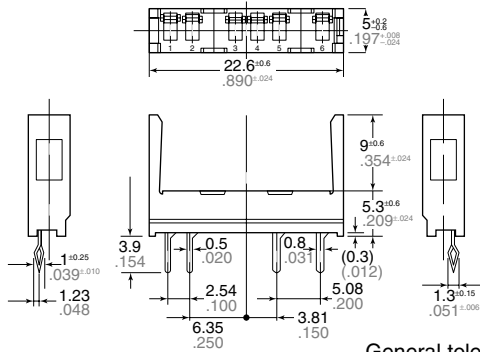

General tolerance: $\pm 0.3 \pm 0.12$

PC board pattern (Bottom view)

PA1a-PS-H

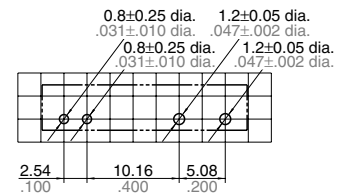

Tolerance: $\pm 0.1 \pm 0.04$

NOTES

1. If it includes ripple, the ripple factor should be less than 5%.
2. Specification values for pick-up and drop-out voltages are for the relay mounting with its terminals below.

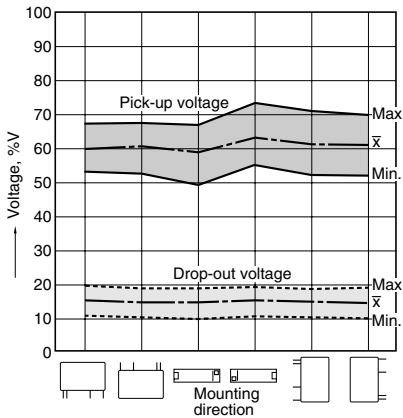

3. When mounting the relays within 1 mm .039 inch, please notice the condition below.

1) Mount the relays in the same direction.

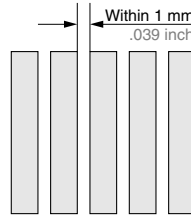

2) Coil terminals (Terminal No. 1 & 2) polarity should be arranged in the same direction.

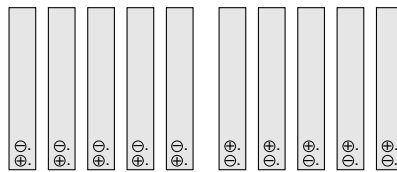

3) Allowable contact current is 2 A.

- 4) About the electrical life for close mounting, please refer to data below.

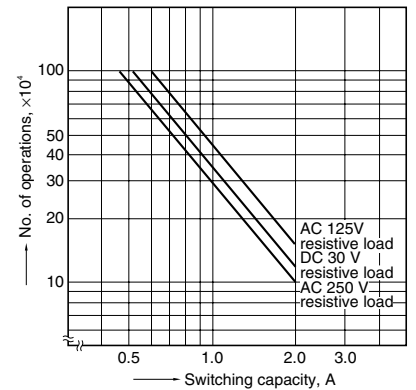
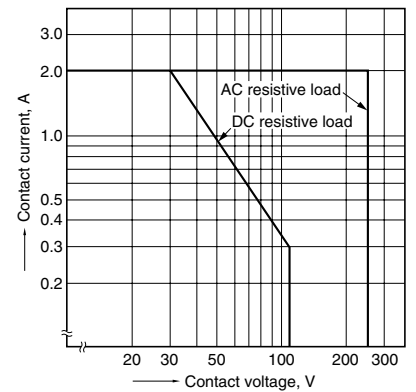

For Cautions for Use, see Relay Technical Information.